

3.0 (76.19)

0.5 (12.7)

0

5.0 (127.0)
4.92 (124.96) (LS)

4.18 (106.17)

1.93 (49.02)

Pilot-operated, balanced-piston relief cartridges are normally closed pressure regulating valves. When the pressure at the inlet (port 1) reaches the valve setting, the valve starts to open to tank (port 2), throttling flow to regulate the pressure. These valves are accurate, have low pressure rise vs. flow, they are smooth and quiet, and are moderately fast.

TECHNICAL DATA

Body Type	Line mount
Interface	None
Body Features	Ninety degree
Mounting Hole Diameter	8.6 mm
Mounting Hole Depth	Through
Mounting Hole Quantity	2
Open Cavities	1
Cavity	T-32A
Port Size	1/2" BSPP
Model Weight	1.14 kg.

NOTES *Important:* Carefully consider the maximum system pressure. The pressure rating of the manifold is dependent on the manifold material, with the port type/size a secondary consideration. Manifolds constructed of aluminum are not rated for pressures higher than 3000 psi (210 bar), regardless of the port type/size specified.

PORT DESIGNATORS

Modifiers	Ports
NMV, IS	All Ports: 1/2" BSPP;

CONFIGURATION OPTIONS

Model Code Example: NMV

MODIFIER

- 6061-T651 Aluminum, Buna-N
- IS 65-45-12 Ductile Iron, Buna-N, Blackened

MANIFOLD FACES

FACE GRID

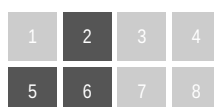

Face 2

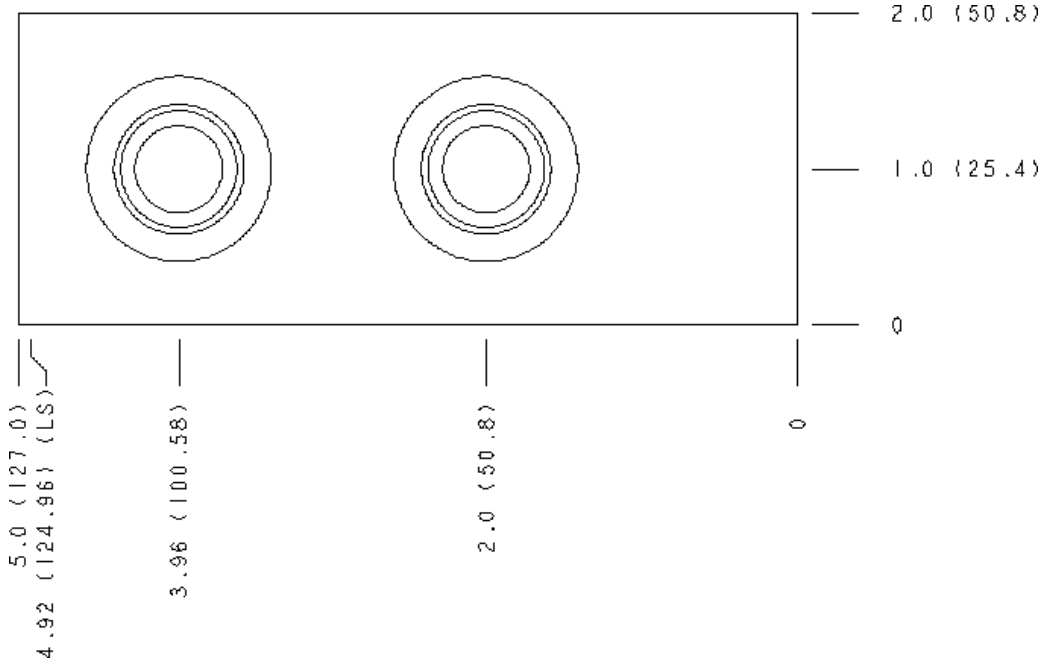

Face 5

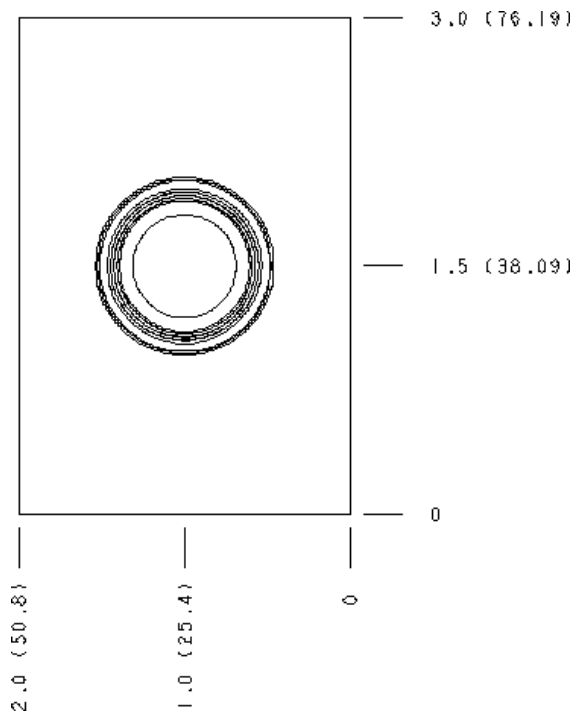

Face 6

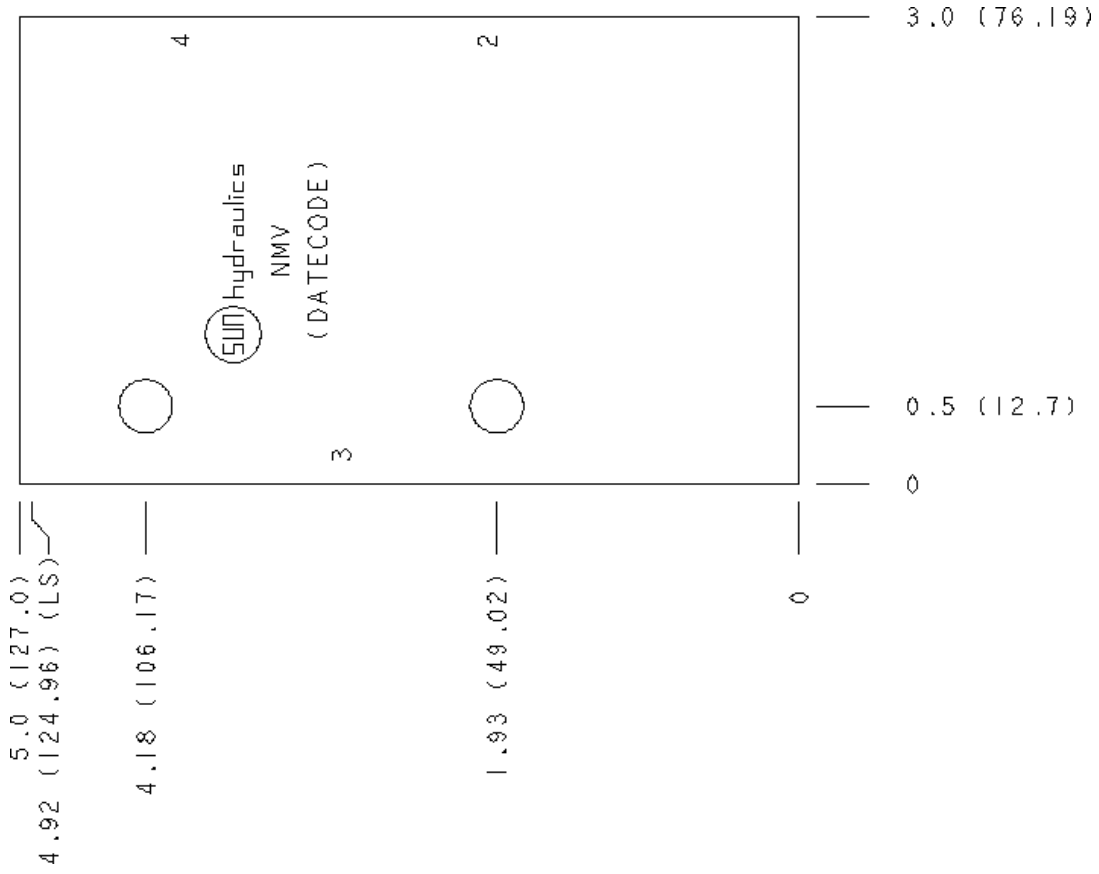

Face 10

