

Solenoid operated poppet valve cartridge

- ◆ solenoid actuated
- ◆ direct operated
- ◆ 2/2- or 3/2-way
- ◆ $Q_{max} = 40 \text{ l/min}$
- ◆ $p_{max} = 350 \text{ bar}$

M22 x 1,5 ISO 7789

- ⊕ II 2 G Ex db IIC T6, T4
- ⊕ II 2 D Ex tb III C T80 °C, T130 °C
- ⊕ I M2 Ex db I Mb
- Class I Division 1
- Class I Zone 1

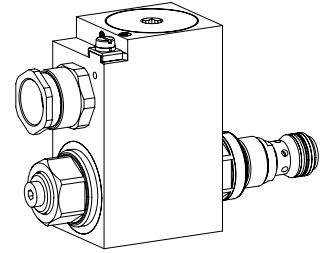

DESCRIPTION

Direct operated 2/2- and 3/2-way solenoid poppet valve in screw-in cartridge construction for cavity according to ISO 7789. By means of the pressure tight switching solenoid, the pressure compensated, metallically sealing poppet spool is either opened or closed. The seat spool guide is sealed by means of an O-ring. The pressure tight encapsulated Ex-protection solenoid coil prevents an explosion on the inside penetrating to the outside as well as an ignitable surface temperature.

APPLICATION

These valves are suitable for applications in explosion-hazard areas, open cast and also in mines. Poppet valves are used where tight closing functions of the valve are essential like leakage-free load holding, clamping or gripping. For machining the cartridge cavity in steel and aluminum blocks, cavity tools are available (hire or purchase). Please refer to the data sheets in register 2.13.

CERTIFICATES

	Surface	Mining	Standard -25 °C to...	Z604 -40 °C to...
ATEX	x	x	x	x
IECEx	x	x	x	x
EAC	x	x	x	x
Australia	x	x	x	x
MA		x	x	
UL / CSA	x		x	x

The certificates can be found on www.wandfluh.com

ACTUATION

Actuation	Switching solenoid, wet pin push type, pressure tight
Execution	MKY45 / 18x60 (data sheet 1.1-183) MKU45 / 18x60 (data sheet 1.1-184)
Connection	Cable gland for cable Ø 6,5...14 mm

Attention! The UL execution is always supplied without cable gland



SYMBOL

„Normally open“ AB

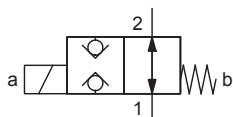

„Normally closed“ BA

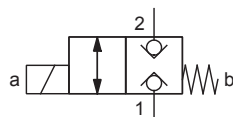

FG

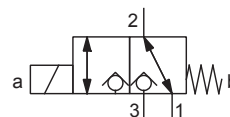

TYPE CODE

		S D Y PM22 - <input type="checkbox"/> - <input type="checkbox"/> / <input type="checkbox"/> <input type="checkbox"/> - <input type="checkbox"/> # <input type="checkbox"/>	
Poppet valve			
Direct operated			
Ex-protection execution, Exd			
Screw-in cartridge M22 x 1,5			
Designation of symbols acc. to table			
Nominal voltage U_N	12 VDC 24 VDC	<input type="checkbox"/> G12 <input type="checkbox"/> G24	115 VAC 230 VAC
			<input type="checkbox"/> R115 <input type="checkbox"/> R230
Nominal power P_N	15 W 17 W 21 W	<input type="checkbox"/> L15 <input type="checkbox"/> L17 <input type="checkbox"/> L21	<i>Ambient temperature up to:</i> 70 °C 70 °C (only UL / CSA) 50 °C
Certification	ATEX, IECEx, EAC Australia	<input type="checkbox"/> <input type="checkbox"/> AU	UL / CSA <input type="checkbox"/> UL MA <input type="checkbox"/> MA
Sealing material	NBR FKM (Viton) NBR -40° C	<input type="checkbox"/> <input type="checkbox"/> D1 <input type="checkbox"/> Z604	(only with 15 W)
Design index (subject to change)	1.11-2064		

GENERAL SPECIFICATIONS

Designation	2/2-, 3/2-way poppet valve
Construction	Direct operated
Mounting	Screw-in cartridge construction
Nominal size	M22 x 1,5 according to ISO 7789
Actuation	Ex-protection switching solenoid
Ambient temperature	Execution L15 / L17 -25...+70 °C (T4) Execution L21 -25...+50 °C (T4) In case of $U_N = 12$ VDC, the max. ambient temperature has to be reduced by 10 °C
Weight	2,25 kg (2/2-way) 2,30 kg (3/2-way)
MTTFd	150 years

HYDRAULIC SPECIFICATIONS

Working pressure	$p_{max} = 350$ bar
Maximum volume flow	$Q_{max} = 40$ l/min, see characteristics
Nominal volume flow	$Q_N = 20$ l/min
Leakage oil	Seat tight, max. 0,15 ml / min (approx. 3 drops / min) at 30 cSt
Fluid	Mineral oil, other fluid on request
Viscosity range	12 mm ² /s...320 mm ² /s
Temperature range fluid	NBR -25...+70 °C FKM (D1) -20...+70 °C NBR 872 (Z604) -40...+70 °C
Contamination efficiency	Class 20 / 18 / 14
Filtration	Required filtration grade $\beta_{6...10} \geq 75$, see data sheet 1.0-50

ACCESSORIES

Threaded body	Data sheet 2.9-2xx
Technical explanations	Data sheet 1.0-100
Filtration	Data sheet 1.0-50
Relative duty factor	Data sheet 1.1-430

MANUAL OVERRIDE

Screw plug (HB0), no actuation possible.
 Optionally HN (K) or HR (K)
 → See data sheet 1.1-311

ELECTRICAL SPECIFICATIONS

Protection class	IP65 / 66 / 67
Relative duty factor	100 % DF
Switching frequency	5'000 / h
Voltage tolerance	± 10 % with regard to nominal voltage
Standard nominal voltage	12 VDC, 24VDC, 115 VAC, 230 VAC AC = 50 to 60 Hz ± 2 %, with built-in two-way rectifier
Standard nominal power	15 W, 17 W, 21 W
Temperature class	Nominal power 15 W / 17 W / 21 W: T1... T4

Note! Other electrical specifications see data sheet 1.1-183 and 1.1-184



COMMISSIONING

Attention! When commissioning, the valve must be vented under pressure (max. two rotations of screw E).



The solenoid coil must only be put into operation, if the requirements of the operating instructions supplied are observed to their full extent. In case of non-observance, no liability is assumed.

STANDARDS

Cartridge cavity	ISO 7789
Explosion protection	Directive 2014 / 34 / EU (ATEX)
Flameproof enclosure	EN / IEC / UL 60079-1, 31
Cable entry	EN 60079-0, 1, 7, 15, 31
Protection class	EN 60 529
Contamination efficiency	ISO 4406

INSTALLATION NOTES

Mounting type	Screw-in cartridge M22 x 1,5
Mounting position	Any, preferably horizontal
Tightening torque	M _D = 60 Nm Screw-in cartridge M _D = 9 Nm knurled nut

Attention! For stack assembly please observe the remarks in the operating instructions



PERFORMANCE SPECIFICATIONS

Oil viscosity $\nu = 30 \text{ mm}^2/\text{s}$

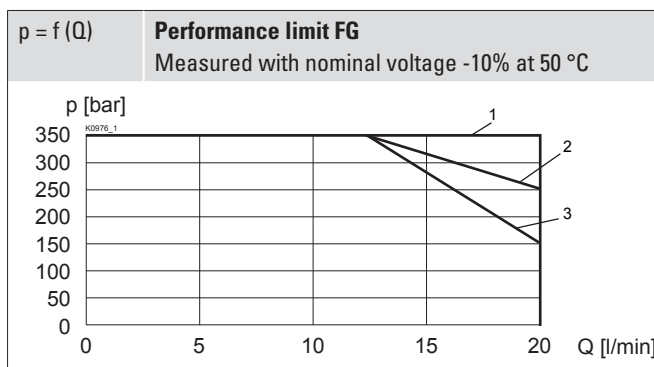
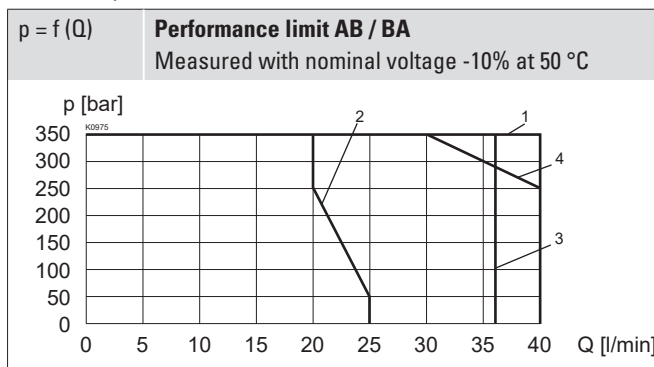

	1 → 2	2 → 1
SDYPM22-AB-L21	2	1
SDYPM22-BA-L21	1	1
SDYPM22-AB-L15 / L17	2	4
SDYPM22-BA-L15 / L17	3	1

	1 → 2	2 → 1	2 → 3	3 → 2
SDYPM22-FG-L21	3	1	1	1
SDYPM22-FG-L15 / L17	3	1	1	2

PERFORMANCE SPECIFICATIONS

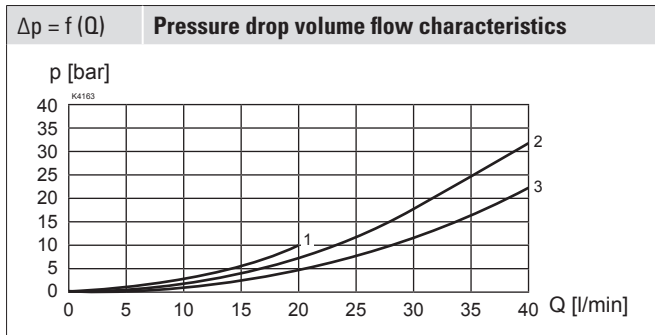
 Oil viscosity $\nu = 30 \text{ mm}^2/\text{s}$

	1 → 2	2 → 1	2 → 3	3 → 2
SDYPM22-AB-...	3	2	-	
SDYPM22-BA-...	3	2	-	
SDYPM22-FG-...	3	3	1	1



Note! With the L15 / L17 execution for ambient temperatures up to 70 °C, the performance specifications have been evaluated with an ambient temperature of 50 °C



Attention! Long periods of non-actuation can reduce the switching performance

ABMESSUNGEN

SDYPM22-AB / BA

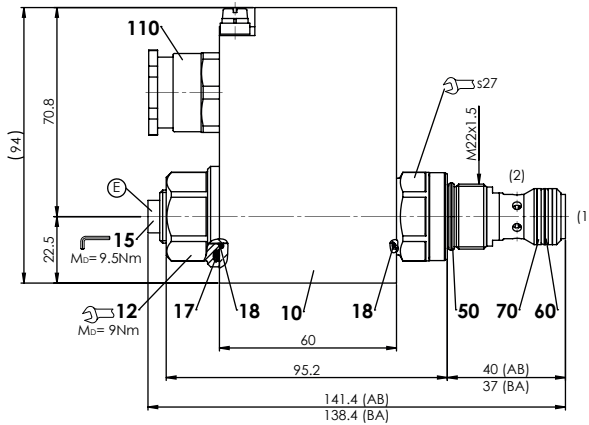

HB4,5

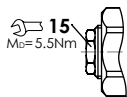

SDYPM22-FG

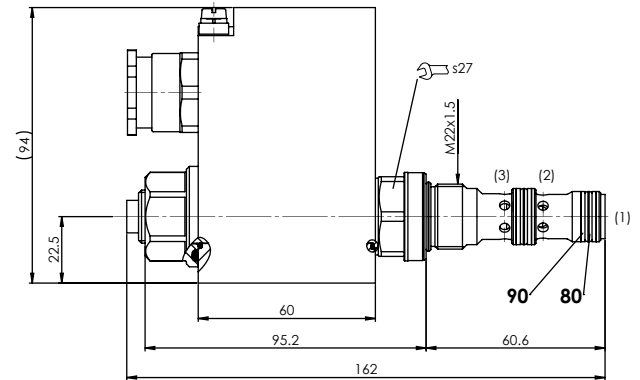
HYDRAULISCHER ANSCHLUSS

Senkungszeichnung nach ISO 7789-22-01-0-98

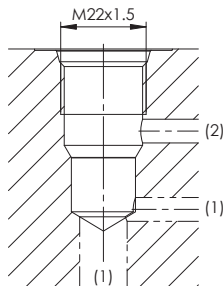
Hinweis!

Detaillierte Senkungszeichnung und Senkungswerkzeug siehe Datenblatt 2.13-1008

HYDRAULISCHER ANSCHLUSS

Senkungszeichnung nach ISO 7789-22-04-0-98

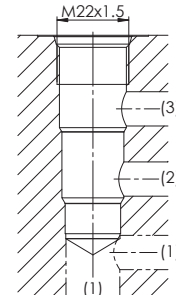
Hinweis!

Detaillierte Senkungszeichnung und Senkungswerkzeug siehe Datenblatt 2.13-1004

PARTS LIST

Position	Article	Description
10	263.6...	Solenoid coil MK.45 / 18 x 60
12	154.2603	Knurled nut Ex M18 x 1,5 x 18
15	239.2033	Screw plug HB0 (incl. seal)
17	160.2251	O-ring ID 25,07 x 2,62 (NBR)
18	160.2170	O-ring ID 17,17 x 1,78 (NBR)
50	160.2188	O-ring ID 18,77 x 1,78 (NBR)
	160.6188	O-ring ID 18,77 x 1,78 (FKM)
60	160.2156	O-ring ID 15,60 x 1,78 (NBR)
	160.6156	O-ring ID 15,60 x 1,78 (FKM)
70	049.8196	Backup ring PTSM rd 14,5 x 17,4 x 1,4
80	160.2140	O-ring ID 14,00 x 1,78 (NBR)
	160.6141	O-ring ID 14,00 x 1,78 (FKM)
90	049.8176	Back-up ring PTSM rd 12,7 x 15,6 x 1,4
110	111.1080	Cable gland M20 x 1,5

SURFACE TREATMENT

- ◆ The cartridge body, the slip-on coil and the armature tube are zinc-nickel coated

SEALING MATERIAL

NBR or FKM (Viton) as standard, choice in the type code